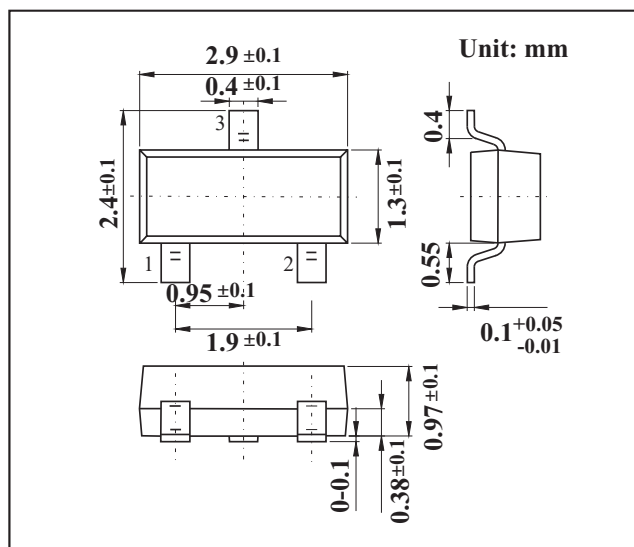

SOT-23 Plastic-Encapsulate Transistors
Features

- Collector Current: $I_c=0.5A$
- NPN Transistors

MECHANICAL DATA

- Case style:SOT-23molded plastic
- Mounting position:any

MAXIMUM RATINGS AND CHARACTERISTICS

@ 25°C Ambient Temperature (unless otherwise noted)

Parameter	Symbol	Rating	Unit
Collector-Base Voltage	V_{CB0}	40	V
Collector-Emitter Voltage	V_{CE0}	25	V
Emitter-Base Voltage	V_{EB0}	5	V
Collector Current -Continuous	I_c	0.5	A
Collector Dissipation	P_c	0.3	W
Junction Temperature	T_j	150	°C
Storage Temperature	T_{stg}	-55 to 150	°C

PACKAGE INFORMATION

Device	Package	Shipping
S8050	SOT-23	3000/Tape&Reel

Electrical Characteristics $T_a = 25^\circ C$

Parameter	Symbol	Testconditions	Min	Typ	Max	Unit
Collector-base breakdown voltage	V_{CB0}	$I_c = 100 \mu A, I_E = 0$	40			V
Collector-emitter breakdown voltage	V_{CE0}	$I_c = 1 mA, I_B = 0$	25			V
Emitter-base Breakdown voltage	V_{EB0}	$I_E = 100 \mu A, I_C = 0$	5			V
Collector-base cut-off current	I_{CBO}	$V_{CB} = 40 V, I_E = 0$			0.1	μA
Collector-emitter cut-off current	I_{CEO}	$V_{CE} = 20 V, I_B = 0$			1	μA
Emitter-base cut-off current	I_{EBO}	$V_{EB} = 5 V, I_C = 0$			0.1	μA
DC current gain	h_{FE}	$V_{CE} = 1 V, I_c = 50 mA$	120		400	
		$V_{CE} = 1 V, I_c = 500 mA$	50			
Collector-emitter saturation voltage	$V_{CE(sat)}$	$I_c = 500 mA, I_B = 50 mA$			0.6	V
Base-emitter saturation voltage	$V_{BE(sat)}$	$I_c = 500 mA, I_B = 50 mA$			1.2	V
Transition frequency	f_T	$V_{CE} = 6 V, I_c = 20 mA, f = 30 MHz$	150			MHz

 $h_{FE}(1)$ Classification

Type	S8050	S8050-L	S8050-H	S8050-J
Range	200-350	120-200	144-202	300-400
Marking	J3Y			

RATINGS AND CHARACTERISTIC CURVES

